

1. **What kind of credit cards can I use on-line?**

Ordering on-line at [www.ScuolaDelCuoio.com](http://www.ScuolaDelCuoio.com) is easy. We accept Visa, MasterCard, American Express and Diners. Soon to come (Sept '09) Paypal.

---

2. **How can I view the prices of Scuola del Cuoio products in Dollars instead of Euros?**

On each page of the website on the lower left hand side, there is a drop down menu entitled "Show prices in." Chose either Euros or Dollars and the price of the product will automatically change to fit your choice.

---

3. **I don't like to order on-line, can I purchase products some other way?**

Yes.

You can write directly to [info@ScuolaDelCuoio.com](mailto:info@ScuolaDelCuoio.com) and place your order with the marketing department. You will then receive a Fax Order Form that you can fill out with your credit card information and authorized signature to be faxed back to Scuola del Cuoio at: +39-055-248-0337.

---

4. **I would like to have a monogram put on the merchandise I just purchased. How can I can get a monogram and how much does it cost?**

The price of monograms vary. When it's not complementary, it generally ranges between one and two Euros. In order to place a monogram on the merchandise you have just purchased, simply chose either "engraved" or "embossed" from the drop down menu entitled "Monogram." If this option is not available send us a written request at [info@ScuolaDelCuoio.com](mailto:info@ScuolaDelCuoio.com) including:

- Personalized monogram order (up to five letters)
- Gilded or Embossed
- With or without periods after the initials
- Location of the monogram on merchandise

Please be aware that our refund and exchange policy does not cover personalized merchandise, in choosing to monogram your product you waive the rights to return or receive a refund on your purchase.

---

5. **I got caught in the rain with my soft leather jacket on - it is now wrinkly. What do I do?**

The jackets are pre-treated for normal weather conditions. If you get caught in a snowstorm or in the rain (clearly days NOT to wear the jacket) allow the jacket to dry naturally (no heat or other). After drying naturally, if it shows signs of wrinkling it can be treated with a light iron using a piece of tissue paper as a buffer. Iron the exterior of the jacket with the tissue as the buffer, being careful not to iron the interior lining as it will melt.

---

6. **I got caught in the rain with my crocodile bag and now I have stains on the bag. What do I do?**

If you were caught in the rain with your crocodile bag, we will now advise you about "damage control" as there is not any permanent solution for reversing the effects of the rain stains on your bag. Master Craftsman Sig. Chiti of Scuola del Cuoio advises that Crocodile bag can be treated with dry wax only. He suggests the KIWI brand (which is available in the U.S.)

Again, it is very important to use DRY hard wax only, preferably the color of the bag. NEVER use creams, oils or gelatinous kinds of treatments on a crocodile bag or the bag will be permanently damaged.

The dry wax should be the same color of the bag and applied then shined with a soft cloth (like those used for cleaning eyeglasses.) After the dry wax is applied and shined the crocodile will become brilliant and luminous. The shining of the bag and treating with the wax may help the overall appearance and tone down those "stains".

---

7. **My new suede jacket is "shedding." Is this normal?**

You need not worry. When brand new, suede tends to "shed" at the beginning - but just the first times that you wear the jacket. Over time this will stop. In these first "wears" of the new season, try to avoid wearing dark colors. When the shedding happens you can pass over your clothes a soft piece of foam that will pick up the little fuzz. In addition, if you gently wipe down the jacket with foam the suede will shed substantially less. However, the fuzz shedding is a normal part of the first time uses of the garment.

We recommended using a polyfoam, similar to those sold in fabric stores to pad chairs or sofas, to pick up the fuzz. It often comes in large square chucks but is also available in thin sheets.

---

8. **Is there anything that I should treat my leather jacket with periodically (such as saddle soap, mink oil, etc.) and how often?**

Scuola del Cuoio jackets and coats have been pre-treated to maintain its quality for the lifetime of the coat and/or jacket. Further treatments, if not required by some outside circumstance, may spoil the skin. Just enjoy your jacket... if there is anything abnormal in its aging process please write to us for assistance at: [info@ScuolaDelCuoio.com](mailto:info@ScuolaDelCuoio.com)

---

9. **When I came to Scuola del Cuio, I received the VAT tax free price for my merchandise. Are your prices on the web site with or without VAT?**

For all prices quoted on the website we have already subtracted the VAT tax as they are intended for shipment only inside of the European Union. If you are a resident in the E.U. the VAT taxes will be added before shipment.

10. **I just returned home from my trip to Florence and I bought my merchandise from Scuola del Cuio with the Global Refund Tax Free discount. I haven't received my Tax Free discount yet. What should I do?**

Scuola del Cuio participates (as most store owners in the EU) in offering Tax Free Discount for Tourists. Clients of Scuola del Cuio in Florence who purchase more than €155 worth of merchandise (in one single business day) and take their purchases outside of the European Union are eligible to receive the Tax Free discount for NON-EU citizens.

The company that is used at Scuola del Cuio is called Global Refund and can be found on the Internet at: [www.globalrefund.com](http://www.globalrefund.com). Global Refund, offers this tax free service and works separately and independently from Scuola del Cuio. Therefore, all questions, comment and concerns regarding your refund must be addressed to Global Refund.

The Global Refund web site also has a Questions and Answers Page where it states that refunds during high season can take "approximately 60 days. During low season you can expect a handling time of 3-5 weeks." If for some reason you still feel that your refund was not processed efficiently you can contact Global Refund's Italy Division:

Global Refund Italia Srl

To the attention of: Luigi Gallazzini

Via Tintoretto, 15

I - 21012 Cassano Magnago (VA), Italy

Phone: +39 0331 283 555

Fax: +39 0331 283 698/9

E-mail: [taxfree@it.globalrefund.com](mailto:taxfree@it.globalrefund.com)

Or the Global Refund Headquarters in Sweden:

Global Refund Holdings AB

Faktorv. 9, P.O.Box 10004

SE-434 21 Kungsbacka

SWEDEN

Phone: +46 300 554 00

Fax: +46 300 127 66

[webmaster@globalrefund.com](mailto:webmaster@globalrefund.com)

11. **I am unsure about my coat and jacket size. How can I make sure to order the right size?**

If you are unsure of your size, please consult the two measurement tables below and contact Scuola del Cuio at [info@ScuolaDelCuio.com](mailto:info@ScuolaDelCuio.com) with your measurements (inches or centimeters). Based on the information that you provide, Scuola del Cuio will be able to suggest the best size for you.

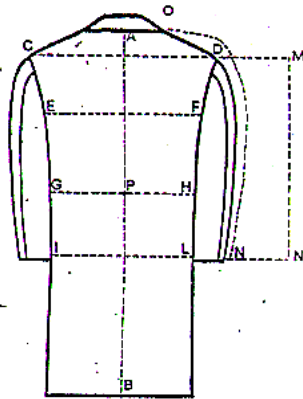

**LADIES OR MENS COAT**  
(MEASURE OVER DRESS OR SUIT)

A - B	TOTAL LENGTH	.....	In.
C - D	WIDTH SHOULDERS	.....	In.
E - F	CHEST (circumference)	.....	In.
G - H	WAIST (circumference)	.....	In.
I - L	HIP (circumference)	.....	In.
M - N	SLEEVE LENGTH (shoulder to wrist)	.....	In.
O - N	SLEEVE LENGTH (neck to wrist for raglan shoulders)	.....	In.
A - P	LENGTH from neck to waist	.....	In.

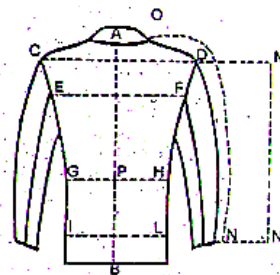

**LADIES OR MENS JACKET**  
(MEASURE OVER SHIRT OR SWEATER)

A - B	TOTAL LENGTH	.....	In.
C - D	WIDTH SHOULDERS	.....	In.
E - F	CHEST (circumference)	.....	In.
G - H	WAIST (circumference)	.....	In.
I - L	HIP (circumference)	.....	In.
M - N	SLEEVE LENGTH (shoulder to wrist)	.....	In.
O - N	SLEEVE LENGTH (neck to wrist for raglan shoulders)	.....	In.
A - P	LENGTH from neck to waist	.....	In.

12. **I want to purchase a bag but the color I want is not available on the website. What are my options?**

If the product you want is not available on the website in a certain color, send us an email at [info@ScuolaDelCuoio.com](mailto:info@ScuolaDelCuoio.com) specifying the changes you would like made. Please note that personalized products or "By request" items are usually subject to a price mark-up that ranges between 10% and 20%.

---

13. **What is CITES?**

C.I.T.E.S. stands for the Convention on International Trade in Endangered Species of Wild Fauna and Flora. CITES is an international agreement between Governments whose aim is to ensure that international trade in specimens of wild animals and plants does not threaten their survival. Scuola del Cuoio uses pelts such as ostrich, lizard and crocodile that are among the list of protected species. Our role in the CITES procedure is to declare that our products, made from such pelts, were bred for commerce and not taken from wildlife. Scuola del Cuoio must send the CITES application and pay the application fee (€16.49) to the local Wild Life and Game Preserve office in Florence before shipping the product. This process can take up to three weeks processing time, but often due to the volume of documents prepared by Scuola del Cuoio the paperwork is completed ahead of time and only needs to pass inspection and officially stamped by the local office. Scuola del Cuoio adheres to the documentation and procedures requested internationally by CITES, but cannot assume responsibility for the possible customs inspection on the part of the U.S. Fish and Wildlife offices once the product reaches the U.S. Often times the product arrives safely to our clients and others are stopped randomly for inspection and can be subject to customs fees in the U.S. as with any of our products. For more information about U.S. Customs Charges and Procedures please refer to Question Number 19. For more information regarding CITES please visit: [www.cites.org](http://www.cites.org)

---

14. **When is Scuola del Cuoio open?**

Monday - Friday 9:30 a.m. - 6:00 p.m.: Workshops and Showrooms

Saturday 9:30 a.m. - 6:00 p.m.: Showrooms only

Sundays during tourist season\* 10:00 a.m. - 6:00 p.m. Showrooms only

\*Please note that Sundays from the end of November to late February Scuola del Cuoio may communicate closures, please check the web-site for updates.

---

15. **How can I visit Scuola del Cuoio?**

Scuola del Cuoio can be reached by its private entrance through the gardens behind the monumental Basilica of Santa Croce or through the Church itself.

16.

Entrance 1 - Through the Gardens: Scuola del Cuoio has a private entrance located at via San Giuseppe, 5r through the gardens behind the Church of Santa Croce. This private entrance allows visitors to also get a rare glance at the exterior monumental apse of the church. Follow the paved path to the small staircase (16 stairs) that lead into the ex-cloister, now Scuola del Cuoio. Once inside, follow the corridor to the very end and enter the workshops and showrooms.

Entrance 2 - Through the Church of Santa Croce: Tickets can be purchased at the ticket booth located along the left side of the main facade. Once inside the Church, follow the right side aisle to the far end (east end) and enter the sacristy. From the sacristy enter the souvenir shop. The entrance to Scuola del Cuoio is just beyond the souvenir shop.

Church Hours for Tourist Visits:

Monday - Saturday: 9:30 a.m. - 5:00 p.m.

Sunday and holidays: 1:00 - 5:00 p.m.

Entrance for Prayer only: Enter at the far end of the left side (north side) of the exterior Church. Chapel reserved for prayer: Monday - Saturday: 9:00 - 6:00 p.m.

Sunday Liturgy Times: 8:00 a.m., 9:30 a.m., 11:00 a.m., 12noon and 6:00 p.m.

17. **Church of Santa Croce Ticket Information:**

Regular admission: €5.00

Reduced admission: €2.00 Visitors 11 - 18 years old, school groups with accompanying professors and tourist groups of over 15 participants.

Free admission: Children under 11 years of age, participants in religious services, disabled visitors and their escorts (ramps are located on the left side (north side) of the exterior of the Church), residents of Florence and authorized tour guides of the city and province of Florence.

For the cost of the ticket, visitors can visit the church, the cloister, the Pazzi Chapel designed by Filippo Brunelleschi and the Church's Museum complex. A small leaflet about the church is also available at the entrance (in English, Italian, Spanish and French). Tickets to the Church of Santa Croce can also be purchased at Scuola del Cuoio.

---

18. **How can I contact Scuola del Cuoio?**

Mailing Address:

Scuola del Cuoio

Piazza Santa Croce, 16

50122 Florence, Italy

Telephone: +39-055-244-533 and +39-055-244-534

Fax: +39-055-248-0337

E-mail: [info@ScuolaDelCuoio.com](mailto:info@ScuolaDelCuoio.com)

---

19. **Which courier do you use to ship your items?**

Scuola del Cuoio products are shipped with DHL couriers and clients are contacted by E-mail with the date of shipment and the tracking number of the parcel. Packages can be traced on-line at [www.dhl.com](http://www.dhl.com) or by calling 1-800-CALL-DHL. The service normally takes only two business days to reach clients in the U.S. CITES related pelts are subject to Fish & Wildlife inspection and approval and their procedure takes usually two weeks.

20. **What are the shipping costs involved in purchasing on-line with [www.leatherschool.com](http://www.leatherschool.com)?**

Scuola del Cuoio uses DHL couriers to ship and insure all parcel outside of Italy. Shipment is based on weight and volume of the package. For prices, please view the table below.

				
<b>Peso volumetrico</b> (Peso merce + 1 kg.)	<b>Dest. USA</b>	<b>Dest. Hawaii, Alaska, Canada, Giappone</b>	<b>Dest. Europa</b>	<b>Dest. Italia</b>
0 – 500 gr.	€ 31.00	€ 50.00	€ 28.00	€ 21.00
500 gr. – 1 kg.	€ 37.00	€ 55.00	€ 31.00	
1 – 2 kg.	€ 47.00	€ 60.00	€ 41.00	
2 – 3 kg.	€ 52.00	€ 75.00	€ 46.00	€ 29.00
3 – 4 kg.	€ 63.00	€ 90.00	€ 53.00	
4 – 5 kg.	€ 72.00	€ 100.00	€ 57.00	
5 – 6 kg.	€ 77.00	€ 110.00	€ 60.00	€ 45.00
6 – 7 kg.	€ 83.00	€ 120.00	€ 63.00	
7 – 8 kg.	€ 89.00	€ 125.00	€ 70.00	
8 – 9 kg.	€ 94.00	€ 130.00	€ 72.00	
9 – 10 kg.	€ 102.00	€ 135.00	€ 80.00	€ 60.00
10 – 15 kg.	€ 140.00	€ 180.00	€ 110.00	
15 – 20 kg.	€ 180.00	€ 215.00	€ 135.00	
+ 20 kg	€ 220.00	€ 260.00	€ 180.00	

Please be aware that these shipping costs are estimates and are subject to change.

21. **What are the insurance charges?**

Each parcel is insured for 2% of the overall value of the merchandise. This 2% charge is added onto to the rates quoted in the above DHL Shipping Table.

22. **I paid for my item to be shipped by Scuola del Cuoio and now DHL has sent me a bill for customs. Why did I receive this bill?**

Unfortunately, some packages (less than 30% of those sent from Florence) are randomly stopped and taxed by the U.S. government customs agents. This is not dependent on the shipping, handling, or insurance that was included in your shipment from Scuola del Cuoio. This taxing, conducted by the customs where your package cleared, is similar to being chosen for a search at the airport when clearing customs. There is not any way of knowing in advance and there is not any way of anticipating this bill.

The U.S. customs officials have their quotas for their volume of packages that they choose to search and tax. Again, this taxing is completely independent of your purchase and shipping from Scuola del Cuoio.

23. **I think there is a defect in my product. What is your product warranty policy?**

Scuola del Cuio products have a six-month warranty from the time of purchase or receipt of the product that covers defects found in the product only. The six-month warranty does not cover products that were damaged in any way by the use or misuse of the product. This six-month all-inclusive warranty for defective goods includes: DHL shipping (two-way), shipping insurance, and all repairs. In all cases, Scuola del Cuio reserves the right to analyze the defect either by photos or digital photos sent by the client with the on-site artisans to determine if the product is defective or shows sign of consumer damage. In the case that the product is not determined defective, but rather shows signs of consumer damage, the object can be repaired and shipped back to the client at the cost of the client (cost of repairs and cost of DHL two-way shipping). For defective products, we kindly ask you to contact us by E-mail: [info@ScuolaDelCuio.com](mailto:info@ScuolaDelCuio.com), telephone: +39-055-244-533 or fax: +39-055-248-0337

Due to very explicit rules and regulations regarding customs and duties, Scuola del Cuio can only authorize the receipt and shipment of packages with DHL couriers. All unauthorized packages that arrive at Scuola del Cuio will be refused.

Shipping authorization requires Scuola del Cuio to send its clients the Company Client Number for authorization. To obtain DHL shipping authorization, please contact Scuola del Cuio at: [info@ScuolaDelCuio.com](mailto:info@ScuolaDelCuio.com), telephone: +39-055-244-533, fax: +39-055-248-0337.

---

24. **What is your refund policy?**

If a Scuola del Cuio product does not meet customer satisfaction for any reason (size, color, product in general), Scuola del Cuio must receive a registered letter within ten days of purchase or receipt of the merchandise. Scuola del Cuio will replace the product or provide a refund of the merchandise less the initial shipping charges, the shipping charges to receive the returned merchandise in Italy and credit card commissions.

Mailing address:  
Scuola del Cuio di Firenze  
Piazza Santa Croce, 16  
50122 Florence, Italy

Upon receipt of the registered letter, the client will be contacted with specific procedures to return the merchandise, including shipping authorization (see below).

Important note: The Refund and Exchange policy is not applicable on personalized or customized products. Customized products include but are not limited to: custom sized products, custom colours for a specific item(s) or monograms of any kind.

Due to very explicit rules and regulations regarding customs and duties, Scuola del Cuio can only authorize the receipt and shipment of packages with DHL couriers. All unauthorized packages that arrive at Scuola del Cuio will be refused.

Shipping authorization requires Scuola del Cuio to send its clients the Company Client Number for authorization. To obtain DHL shipping authorization, please contact Scuola del Cuio at: [info@ScuolaDelCuio.com](mailto:info@ScuolaDelCuio.com), telephone: +39-055-244-533 or fax: +39-055-248-0337

---

25. **I purchased an evening bag from Scuola del Cuio in 1991 and I noted that the clasp has broken. Do you repair items purchased from Scuola del Cuio?**

Scuola del Cuio provides lifetime assistance on all products in the case of repairs or other maintenance issues. The Lifetime Product Assistance does not include the cost of repairs and the two-way DHL shipping and insurance. Important note: For all products that require assistance, even outside of the warranty period, it is imperative to follow Scuola del Cuio's Shipping policy.

Due to very explicit rules and regulations regarding customs and duties, Scuola del Cuio can only authorize the receipt and shipment of packages with DHL couriers. All unauthorized packages that arrive at Scuola del Cuio will be refused.

Shipping authorization requires Scuola del Cuio to send its clients the Company Client Number for authorization. To obtain DHL shipping authorization, please contact Scuola del Cuio at: [info@ScuolaDelCuio.com](mailto:info@ScuolaDelCuio.com), telephone: +39-055-244-533 or fax: +39-055-248-0337.

---

26. **I would like to mail you a package with my purse for repairs. How do I do I ship something to Scuola del Cuio?**

Due to very explicit rules and regulations regarding customs and duties, Scuola del Cuio can only authorize the receipt and shipment of packages with DHL couriers. All unauthorized packages that arrive at Scuola del Cuio will be refused.

Shipping authorization requires Scuola del Cuio to send its clients the Company Client Number for authorization. To obtain DHL shipping authorization, please contact Scuola del Cuio at: [info@ScuolaDelCuio.com](mailto:info@ScuolaDelCuio.com), telephone: +39-055-244-533 or fax: +39-055-248-0337.

---

27. **How long does it take to receive a shipment from Scuola del Cuio?**

Scuola del Cuio hand-makes all its products and have a small inventory of products for immediate sale. If a product is available in stock, its shipment is usually made in 48 hours unless a CITES document (see question 13) is required. You can expect therefore to receive the parcel within a week from the order. If the product is not available, the production time may vary from two weeks to 8 weeks, depending on availability of needed materials and skins. You may want to request by e-mail an estimate about the delivery timing for a specific product before placing the order. When a product is subject to CITES regulation, Italian *Corpo Forestale* takes 10 days to release the export permit, while Fish & Wildlife offices at destination take between ten and 20 days to inspect and approve the import. The overall delivery process can therefore take up to 35 work days. We keep each parcel we shipped screened until it's delivered to ensure the minimum loss of time during Custom clearance procedures.